

535 machine information

The Pronova 535 bag packaging machine is a robust and sturdy stainless steel machine that automatically and without moving parts opens up and seals prefabricated Joker bags. It is designed for 24-hour-use in automated packaging lines. Heavy products can be packaged –vertically as well as horizontally, if using the optional supporting conveyor belt. The machine has proven to be reliable in tough environments and can be thoroughly rinsed.

With the patented Sesam opening rails you are able to have many bags open at a time for filling. By turning two knobs you can instantly and very easily change the bag opening and adjust it to the product's size and shape – from a very narrow and thin up to a square opening.



Flexibility

Highly versatile design –easily adjusted to suit the product. Opening rails can be ordered from one up to five meters long.

A large variety of bag sizes –from 50 up to 800 mm wide bags.

Many different bag applications
–reclosability, perforation, headers, pin-packs, etc.

Continuous or intermittent bag feed.

Automating your packaging

The machine can be connected to most weighing systems, volume fillers and product counters for random filling.

With continuous product flows from diverse production machines or handling equipment, Pronova can supply product counter and units to collect the products while pulling a new bag in position.

For oriented products, bags can be perfectly opened to fit the shape of the product and then firmly held in position to create a tight package. By filling more than one bag at the time, the capacity of intermittent feeding can be up to 60 bags per minute. The speed can be even higher when filling at continuous motion. The PLC can communicate with a Scada system for collecting information. Pronova has the experience it takes to design and supply customized automated filling units.

PLC system

The machine is equipped with a Mitsubishi Melsec PLC system. The operator panel gives all necessary machine information and its touch-button display with universal symbols is highly operator-friendly.

Standard features:

- Preset counter for automatic stop after preset number of bags.
- Automatic intermittent bag feeding with adjustable stop time.
- Preset counter for number of bags per feed.
- Continuous feeding of bags.
- Out- and inputs for communicating with auto. lines.

Options

- Speed control for bag feeding.
- Printers.
- Label equipment.
- Counters.
- Air evacuation.
- Compression unit.
- Unit for cleaning contaminated sealing surfaces.



PRONOVA
PACKAGING SYSTEMS

The Pronova 535 bagging machine

– horizontal or vertical filling, with or without the conveyor belt

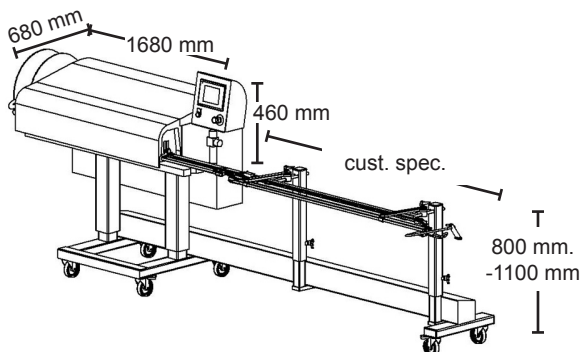

Basic with Sesam – alt. Classic opening rails. These rails can be made very short if the space is limited and up to 5 meters for the case of many operators or filling positions. Filling can be done vertically, horizontally or in any angle in between.

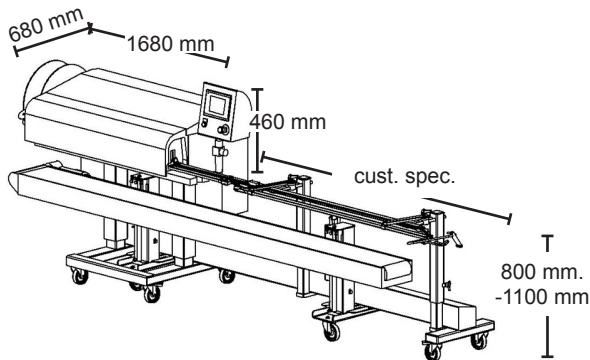

With supporting conveyor belt for heavy products. Bags can hang free without support up to a weight of 300-400 grams per 100 mm bag width. For heavier products, we recommend the conveyor belt for support. There are also limitations for the total weight that strains the opening rails.

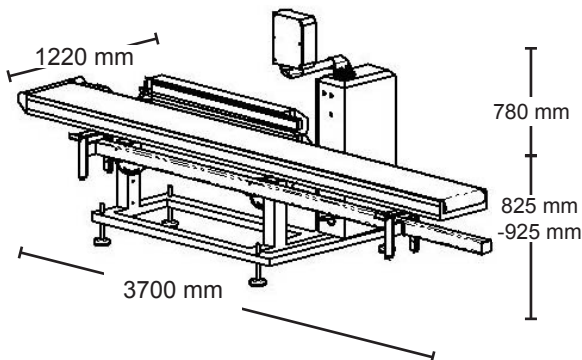

Horizontal, for horizontal filling of products that need to be positioned in a certain way, or products that need extra careful handling.

All three designs can be added with labellers or imprints straight onto the bags. This is done on empty bags prior to the point of filling.

Technical specifications Pronova 535

Machine weight:	Approx. 300 kg
Max. sealing speed:	30 m./min.
Standard sealing speed:	12 m./min
Power:	2,5 kW
Electrical supply:	400 V 3-phase
Compressed air:	500 kPa, 0,06 m3/h

QUALITY

The patented Pronova Packaging Systems stand for quality and responsibility.

Every step of the way is guided by the ISO 9001 standards –from the designing and production of our machines and packaging material through to delivery, service, education and personal treatment.

Our machines are CE-marked.

The packaging machines are all through designed with few moving parts and with a simplicity that makes them easy to operate and maintain. The sealing unit is easily dismantled without the use of any tools.

Our licensees and distributors are all equally taking full responsibility for delivered machines and material, and they all possess good skills in installation, education and service.

JOKER

For further information, don't hesitate to contact us:

Pronova AB
Olofsdalsvägen 26
302 41 Halmstad
Sweden

Tel: +46 (0)35 17 19 00

Fax: +46 (0)35 17 19 19

sales@pronovaab.se
www.pronovasweden.eu